

EF3415 – Sleep’O’Meter

The purpose of this application is to track the movements of the subject while is sleeping. If the subject has a good sleep the it will not move to many times during the night. In the cases when the subject is disturbed by external factors like noise/light/vibrations frequent moves will occur. Also in the case when the subject has some health problems frequent moves will occur.

By tracking the moves and the presence of the subject in bad other tasks like counting the number of sleep hours can be performed.

The project uses a sensor that is placed in bed, on the mattress and the EVM demo module KIT33794DWBEVM based on MC33794 and 908QY4 CPU. The main application is reading the data from the demo module thru the serial port and is displaying it on the screen. The data can be recorded and saved and a Plot showing the active sensor for each minute can be created using the collected data.

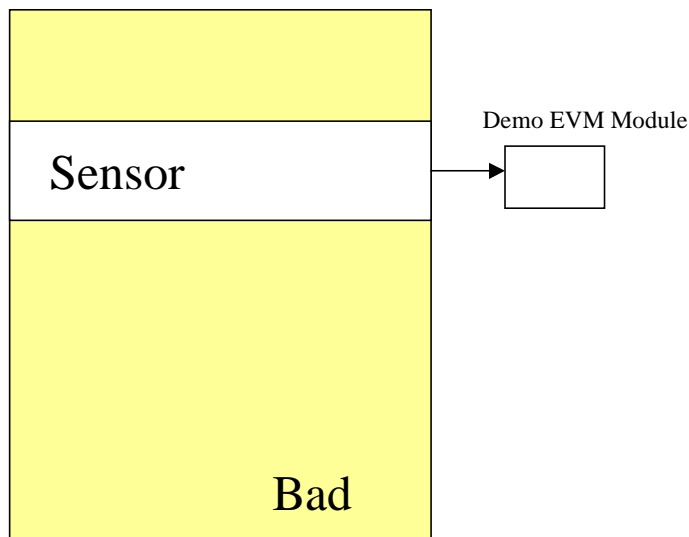
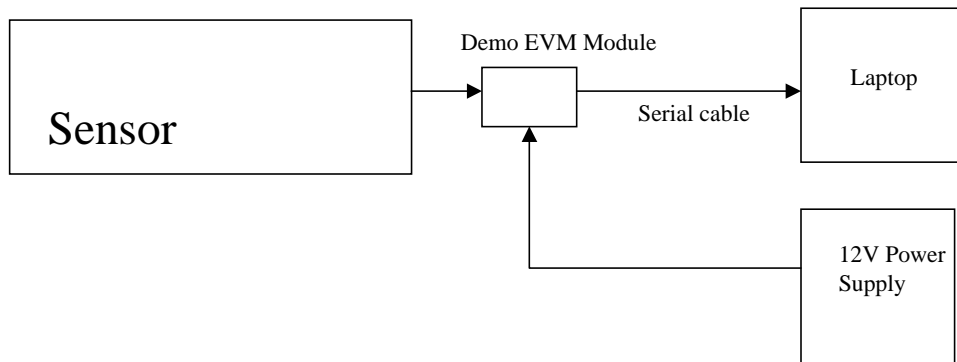

The setup is quite simple – place the sensor on the mattress, connect the sensor, the power and the serial cable to the EVM module. Connect the serial cable to the computer and start the EVM_log Excel program.

Press the start Button and the readings from the sensors will show up on the screen.

This screen can be used for the initial debug of the sensor – place your hand in different regions of the sensor and check the result on the screen.

Once the recording is done press the Compute Average Button in order to get the results – the Average sheet will be populated with the average readings for each minute and the Position versus Time Chart will be created.

The Chart will show the position of the active sensor over time – in this case sensor no. 9 was placed at the edge of the bed and sensor no. 1 was at the opposite end.

As you can see from this chart something disturbed the subject about 2.35AM – in this case some noisy neighbors coming back from a party.

By analyzing the Charts obtained for different nights a clear connection can be made between the number of movements in bed, the disturbing factors and the quality of the sleep.

Out 1	Out 2	Out 3	Out 4	Out 5	Out 6	Out 7	Out 8	Out 9	Log	Log Position	Log at 1 Second
TRUE	TRUE	TRUE	TRUE	TRUE	TRUE	TRUE	TRUE	TRUE	TRUE	30975	TRUE
164	163	164	163	166	163	158	162	125	Value		

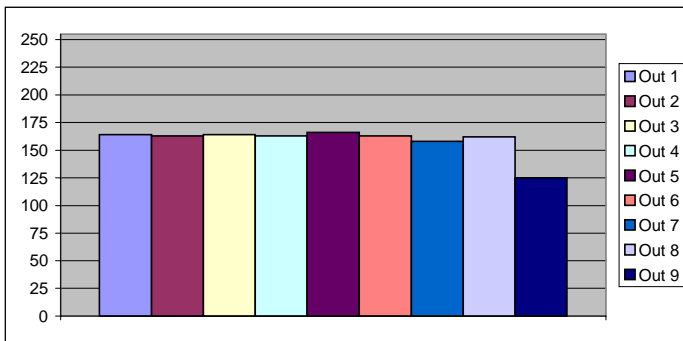

Compute Average

Start

Position VS Time

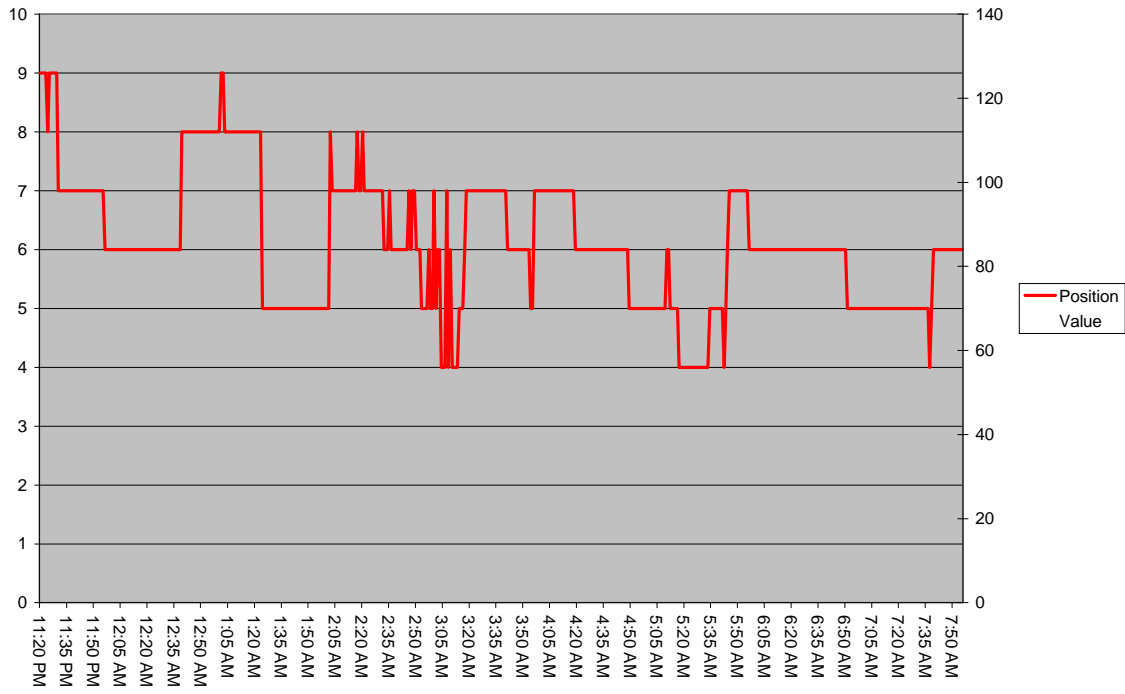

Hardware

The hardware consist in a Sensor built on a piece of Vinyl/Textile material and the EVM Module. Vinyl/Textile material is flexible and is available for sale at Wal-Mart Stores.

The sensor elements are built from thick aluminium foil.

Because the size of the sensor is the size of the bed shielding was a must.

Each sensor is connected to a thin copper wire using a piece of cardboard and a couple of staples. In order to release the stress the wires are bended in an S-shape and then are routed to the shield area. The shield area is another piece of thick aluminium foil connected to the shield output of the EVM module. Everything is fixed with tape.

So the whole sensor has 10 connections – sensor1...sensor 9 and shield.

All the connections are routed to a flat connector towards the EVM – like that the Sensor-EVM assembly caan be disconnected/connected very easy.

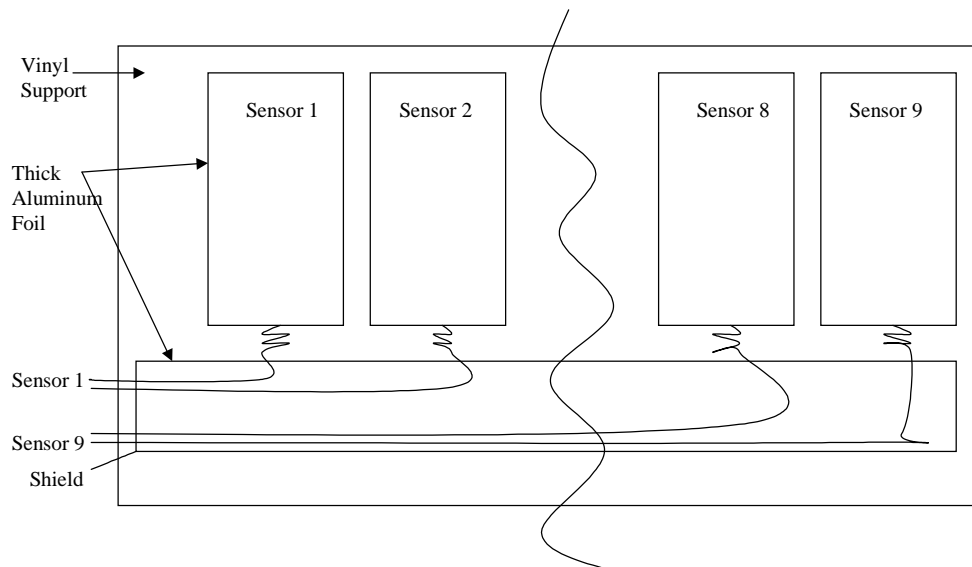



The EVM module is built around the MC 33794 Electric Field Imaging Device. The MC 33794 allows the sensing of objects in an electric field it generates by driving a voltage through an internal resistance to electrically conductive electrodes and measures the voltage at the electrode pin. An object moving into the field with a dielectric constant different than the medium it is in will change the capacitance between the electrodes creating the field. The amount of capacitance between the electrodes and conductive elements connected to the circuit ground return will effect the measured voltage because the voltage drop across the resistor is proportional to the current through it, and the current through it is proportional to the capacitance.

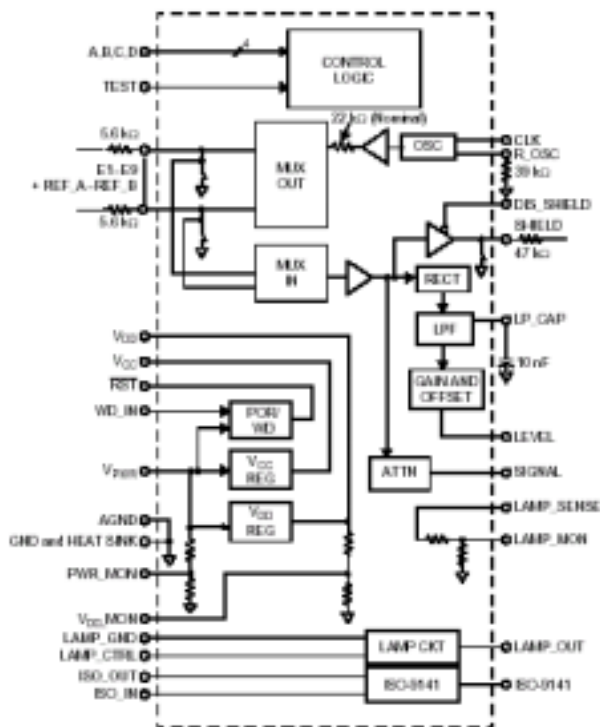

The schematic diagram of the EVM module is a typical application for the MC 33794 IC. The Sensor IC is connected to the 908QY4 CPU – the Sensor in IC is reading the Sensor 1 to Sensor 9 inputs and is delivering the analog signal to the CPU. The CPU is measuring the signal using the integrated 8 bit AD and is delivering the signal level to the Serial Port.

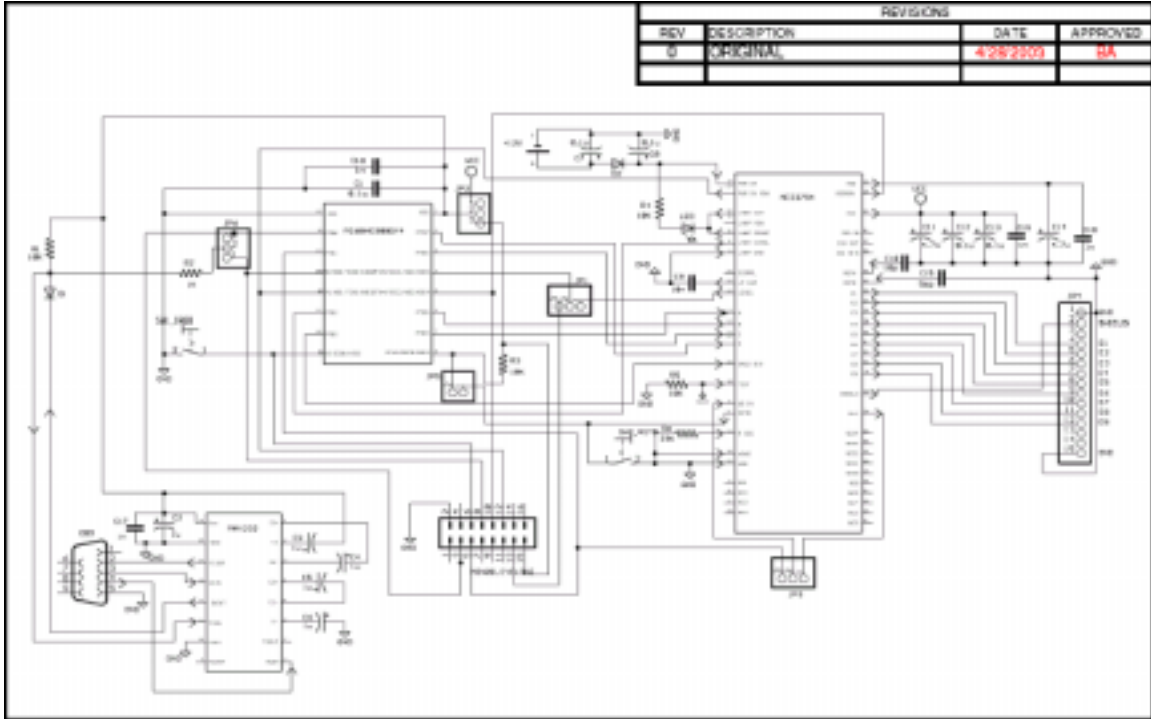

Software

The data collection software is the main part of this project.

Excel was easy to use and is offering support for data storage/charts and VBA modules.

The LogEVM.xls file contain 4 worksheets and a VBA module.

The Results worksheet present the collected data in real time for immediate examination.

Also three Buttons are present:

- Start Button to start data collection
- Compute Average Button to compute the average readings (at one minute) and display the Position vs. Time Chart
- Delete Log! Button used to delete All the collected data. This Button is hidden in the right side of the worksheet.

The Log worksheet contains the time in seconds from midnight, the time in AM/PM format and 9 columns for the readings from the sensors. A line is added to this table for each second when recording is on.

83999.25	11:19:59 PM	42	163	165	166	165	164	158	162	49
84000.3	11:20:00 PM	165	165	165	167	165	163	159	161	46
84001.29	11:20:01 PM	166	163	165	166	166	163	159	160	47
84002.28	11:20:02 PM	165	164	166	166	167	163	159	161	40
84004.64	11:20:04 PM	166	164	166	166	0	163	157	161	45
84005.3	11:20:05 PM	166	163	166	166	166	164	157	161	46
84005.9	11:20:05 PM	165	163	165	167	165	164	158	161	45
84006.56	11:20:06 PM	165	164	166	166	165	164	159	162	40
84007.27	11:20:07 PM	166	163	165	166	165	163	158	160	47
84008.26	11:20:08 PM	166	164	166	166	166	163	159	161	39
84009.31	11:20:09 PM	166	164	164	167	165	164	157	160	40
84010.29	11:20:10 PM	165	164	166	165	165	163	158	161	40
84011.28	11:20:11 PM	165	163	166	166	167	163	158	160	49
84012.27	11:20:12 PM	166	163	166	167	166	163	158	163	161
84013.26	11:20:13 PM	166	164	165	167	166	163	159	163	163
84014.3	11:20:14 PM	165	165	166	165	165	164	158	165	161

The Average worksheet contains the time in seconds from midnight, the time in AM/PM format, 9 columns with the average readings from the sensors, the number of seconds for the average period and minimum value + minimum value sensor number. This table is generated from the Log table by averaging the sensor reading values for each minute. The Average1() Subroutine create this table and the Position vs. Time Chart. The chart uses the Time and minimum value sensor number columns to create the final result for the collected data.

84058.3	11:20:58 PM	166.45	165.9	169.05	170.25	166.2333	166.75	128.8833	155.6333	104.6667	60	104.6667	9
84118.22	11:21:58 PM	171.2667	168.4	171.7167	173.4833	171.4167	168.6167	126.2667	109.0833	87.58333	60	87.58333	9
84178.26	11:22:58 PM	171.2167	168.2167	171.4167	173.2667	171.3	168.6833	119.5667	106.95	88.3	60	88.3	9
84239.22	11:23:59 PM	170.9344	167.9344	171.2787	173.0328	170.9344	168.1967	140.4262	102.4918	100.1475	61	100.1475	9
84298.27	11:24:58 PM	170.5932	167.9661	170.9831	173.0508	170.9153	167.9322	144.5593	99.16949	100.1525	59	99.16949	8
84358.3	11:25:58 PM	170.7667	167.7333	170.95	172.7667	170.8667	167.8333	143.85	98.5	97.98333	60	97.98333	9
84418.28	11:26:58 PM	170.4667	167.1833	170.95	172.55	170.65	167.6333	143.7	98.81667	97.01667	60	97.01667	9
84478.26	11:27:58 PM	170.3833	167.3167	170.6667	172.7667	170.3	167.7	143.2333	98.28333	96.95	60	96.95	9
84538.29	11:28:58 PM	170.2667	167.3833	170.5167	172.5167	170.5167	167.6833	143.05	97.53333	96.4	60	96.4	9
84598.27	11:29:58 PM	170.1333	167.3	170.55	172.3	170.5833	167.6167	138.15	98.63333	96.08333	60	96.08333	9
84658.31	11:30:58 PM	168.7667	166.5667	169.35	169.6833	124.2833	103.2167	59.63333	145.9833	131.4	60	59.63333	7

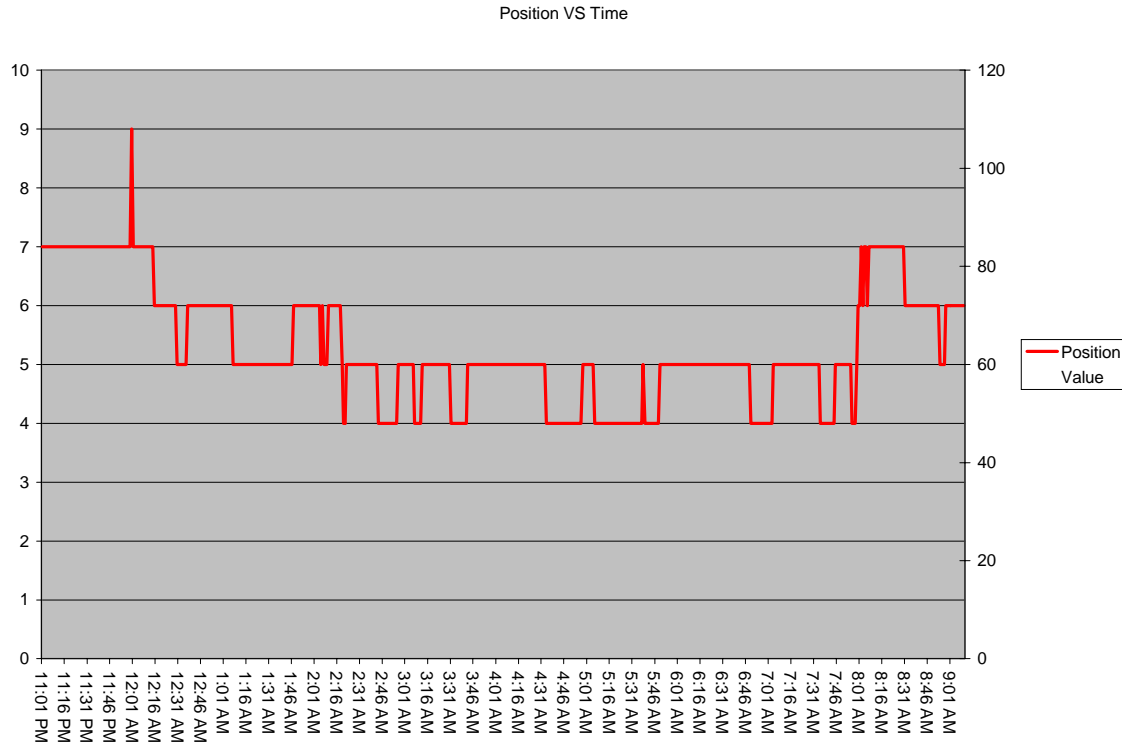

The VBA Module contains subroutines for Data Collection, a Form that is presenting the data in real time and a subroutine to compute the average values of the data for each minute and display the chart.

Serial port COM1:9600/N/8/1 is used for communication with the EVM module.

The MSComm object is used for serial communication.

The StartSerial() subroutine open the serial connection and initialize the MSComm object.

```

Set MSCommXX = New MSComm
With MSCommXX
    .CommPort = 1
    .Handshaking = 0
    .RTSThreshold = 1
    .RTSEnable = True
    .Settings = "9600,n,8,1"
    .SThreshold = 1
    .PortOpen = True
    .InputLen = 0 'every character in the buffer is returned

```

The protocol used By the EVM over the serial line is:

```

>Driver 1    'set shield driver on
>S 1        ' select electrode nr. 1
>X          ' Read the value for electrode nr. 1
>122       ' EVM return the value for electrode nr. 1
>S 2        ' Select electrode nr. 2

```

```

>X
>126
....
>S 9
>X
>144      'EVM return the value for electrode nr. 9

```

The subroutine ReadElectrode(electrode As Byte) is reading the value for each electrode. The routine interrogates the EVM and if the answer from the module is not coming in 1 second a timeout is generated.

This subroutine uses the ParseResult sub to parse the string returned by EVM for each electrode reading.

```

Private Function ParseResult(text As String) As Byte
'parse a 8 char text string returned by EVM serial interface
' return 0 in case of error
' X 0D 0A hexdig hexdig 0D 0A >
If Len(text) < 7 Then
    ParseResult = 0
    Exit Function
End If
If Mid(text, 1, 1) <> "X" Then
    ParseResult = 0
    Exit Function
End If
If Mid(text, 2, 1) <> Chr$(13) Then
    ParseResult = 0
    Exit Function
End If
If Mid(text, 3, 1) <> Chr$(10) Then
    ParseResult = 0
    Exit Function
End If
ParseResult = Val("&H" & Mid(text, 4, 2)) ' return value of 2 digit hex reading
End Function

```

The Main Loop of the program uses the ReadElectrode sub to read all the electrodes sequentially. The results are stored in the Log worksheet if Log is true. Each electrode is active if OUT1..OUT9 are TRUE. The starttime variable is used to generate an accurate 1 second interval for the readings (if Log at one Second is True). The values obtained are stored in the Log worksheet.

```

Do While keepgoingin
    DoEvents
    If serialon Then
        ' log at 1 second interval
        If firsttime Then
            starttime = Timer + 1
            firsttime = False
        Else
            starttime = starttime + 1
        End If

        If Worksheets("Results").Cells(2, 1).value Then ReadElectrode (1)
        If Worksheets("Results").Cells(2, 2).value Then ReadElectrode (2)
        If Worksheets("Results").Cells(2, 3).value Then ReadElectrode (3)
        If Worksheets("Results").Cells(2, 4).value Then ReadElectrode (4)
    End If

```

```

If Worksheets("Results").Cells(2, 5).value Then ReadElectrode (5)
If Worksheets("Results").Cells(2, 6).value Then ReadElectrode (6)
If Worksheets("Results").Cells(2, 7).value Then ReadElectrode (7)
If Worksheets("Results").Cells(2, 8).value Then ReadElectrode (8)
If Worksheets("Results").Cells(2, 9).value Then ReadElectrode (9)

' Log the values if logging is active
If Worksheets("Results").Cells(2, 11).value Then
    logpos = Worksheets("Results").Cells(2, 12).value
    ' seconds since midnight
    Worksheets("Log").Cells(logpos, 1).value = Timer
    ' system time
    Worksheets("Log").Cells(logpos, 2).value = Time
    ' values 1-9
    Worksheets("Log").Cells(logpos, 3).value = Worksheets("Results").Cells(3, 1).value
    Worksheets("Log").Cells(logpos, 4).value = Worksheets("Results").Cells(3, 2).value
    Worksheets("Log").Cells(logpos, 5).value = Worksheets("Results").Cells(3, 3).value
    Worksheets("Log").Cells(logpos, 6).value = Worksheets("Results").Cells(3, 4).value
    Worksheets("Log").Cells(logpos, 7).value = Worksheets("Results").Cells(3, 5).value
    Worksheets("Log").Cells(logpos, 8).value = Worksheets("Results").Cells(3, 6).value
    Worksheets("Log").Cells(logpos, 9).value = Worksheets("Results").Cells(3, 7).value
    Worksheets("Log").Cells(logpos, 10).value = Worksheets("Results").Cells(3, 8).value
    Worksheets("Log").Cells(logpos, 11).value = Worksheets("Results").Cells(3, 9).value
    ' increment log position
    If logpos >= 65535 Then logpos = 65535 ' max nr.of rows in excell
    Worksheets("Results").Cells(2, 12).value = logpos + 1
End If

' wait until next second
If Worksheets("Results").Cells(2, 13).value Then
    Do While starttime >= Timer
        DoEvents
        If Timer + 3600 < starttime Then starttime = starttime - 86400 ' skip midnight
    Loop
End If

End If
Loop

```

The code is easy to understand and contain some comments, a part that is more difficult is related to the “skip Midnight” feature - the timer function used returns the number of seconds from midnight. The number will increase from 0 to 86399 and the will reset. Some conditional statements will take care of that – so the program will work correct even over midnight.

Conclusion

The Sleep’O’Meter is a fun project, but it can be a useful tool for examining the sleep behavior of individuals in different conditions.

Resources

MC33794 reference sheet –www.motorola.com
KIT33794DWBEVM.PDF – kit documentation
MS VBA Help

VBA Module Listing

```
' Under Tools/References Set: Microsoft Comm Control 6.0
Public MSCommXX As Variant
Public keepongoin As Boolean 'TRUE as long as the program is running
Public serialon As Boolean 'TRUE as long as a serial port is open and assigned to
MSCommXX
Public serialform As Boolean 'TRUE as long as SerialMonitor Form is active
Public Waittime As Single
Public sensorread As Byte
```

```
Sub MAIN()
Dim intext As String
keepongoin = True
serialon = False
serialform = False
```

```
SerialFormOpen
Waittime = Timer + 1
If Waittime > 86400 Then Waittime = Waittime - 86400 ' skip midnight
```

```
'test for parseresult a = ParseResult("X" & Chr$(13) & Chr$(10) & "FF67")
firsttime = True
```

```
Do While keepongoin
  DoEvents
  If serialon Then
    ' log at 1 second interval
    If firsttime Then
      starttime = Timer + 1
      firsttime = False
    Else
      starttime = starttime + 1
    End If
```

```
    If Worksheets("Results").Cells(2, 1).value Then ReadElectrode (1)
    If Worksheets("Results").Cells(2, 2).value Then ReadElectrode (2)
    If Worksheets("Results").Cells(2, 3).value Then ReadElectrode (3)
    If Worksheets("Results").Cells(2, 4).value Then ReadElectrode (4)
    If Worksheets("Results").Cells(2, 5).value Then ReadElectrode (5)
    If Worksheets("Results").Cells(2, 6).value Then ReadElectrode (6)
    If Worksheets("Results").Cells(2, 7).value Then ReadElectrode (7)
    If Worksheets("Results").Cells(2, 8).value Then ReadElectrode (8)
```

```

If Worksheets("Results").Cells(2, 9).value Then ReadElectrode (9)

' Log the values if logging is active
If Worksheets("Results").Cells(2, 11).value Then
  logpos = Worksheets("Results").Cells(2, 12).value
  ' seconds since midnight
  Worksheets("Log").Cells(logpos, 1).value = Timer
  ' system time
  Worksheets("Log").Cells(logpos, 2).value = Time
  ' values 1-9
  Worksheets("Log").Cells(logpos, 3).value = Worksheets("Results").Cells(3,
1).value
  Worksheets("Log").Cells(logpos, 4).value = Worksheets("Results").Cells(3,
2).value
  Worksheets("Log").Cells(logpos, 5).value = Worksheets("Results").Cells(3,
3).value
  Worksheets("Log").Cells(logpos, 6).value = Worksheets("Results").Cells(3,
4).value
  Worksheets("Log").Cells(logpos, 7).value = Worksheets("Results").Cells(3,
5).value
  Worksheets("Log").Cells(logpos, 8).value = Worksheets("Results").Cells(3,
6).value
  Worksheets("Log").Cells(logpos, 9).value = Worksheets("Results").Cells(3,
7).value
  Worksheets("Log").Cells(logpos, 10).value = Worksheets("Results").Cells(3,
8).value
  Worksheets("Log").Cells(logpos, 11).value = Worksheets("Results").Cells(3,
9).value
  ' increment log position
  If logpos >= 65535 Then logpos = 65535 ' max nr.of rows in excell
  Worksheets("Results").Cells(2, 12).value = logpos + 1
End If

' wait until next second
If Worksheets("Results").Cells(2, 13).value Then
  Do While starttime >= Timer
    DoEvents
    If Timer + 3600 < starttime Then starttime = starttime - 86400 ' skip midnight
  Loop
End If

End If
Loop

If serialon Then MSCommXX.PortOpen = False
Set MSCommXX = Nothing ' release serialObject before exit

```

```
End Sub
Private Sub ReadElectrode(electrode As Byte)
Dim intext As String
```

```
    MSCommXX.InBufferCount = 0 ' reset input buffer
    OutText ("S " & Trim(Str(electrode)) & Chr$(13))
    ' S 1, S 2 select active electrode
    TypeText (Chr$(13) & "Elecrode " & Str(electrode) & "=")
    Waittime = Timer + 1 ' timeout to read result
    Do While Timer < Waittime
        DoEvents
        If MSCommXX.InBufferCount Then
            intext = MSCommXX.Input
            'MSCommXX.InBufferCount = 0 ' reset in buffer
            'TypeText (intext & Chr$(13))
            incount = Len(intext)
            For a = 1 To incount
                'TypeText (Mid(intext, a, 1))
                If Mid(intext, a, 1) = ">" Then Exit Do
            Next a
        End If
        If Timer + 3600 < Waittime Then Waittime = Waittime - 86400 ' skip midnight
    Loop
```

```
    MSCommXX.InBufferCount = 0 ' reset input buffer
    OutText ("X" & Chr$(13)) ' request a new reading
    Waittime = Timer + 1 ' timeout to read result
        ' loop to wait the next reading
    Do While Timer < Waittime
        DoEvents
        If MSCommXX.InBufferCount >= 8 Then
            intext = MSCommXX.Input
            MSCommXX.InBufferCount = 0 ' reset in buffer

            'TypeText (intext & Chr$(13))
            'incount = Len(intext)
            'For a = 1 To incount
            ' TypeText (Mid(intext, a, 1) & " " & Hex(Asc(Mid(intext, a, 1))) &
Chr$(13))
            'Next a
            result = ParseResult(intext)

            If result <> 0 Then
                TypeText (Str(result))
```

```

        Worksheets("Results").Cells(3, electrode).Value = result
    Else
        TypeText (intext & Chr$(13))
        TypeText (Chr$(13))
        incount = Len(intext)
        For a = 1 To incount
            TypeText (" " & Hex(Asc(Mid(intext, a, 1))))
        Next a
        TypeText (Chr$(13))
    End If
    Worksheets("Results").Cells(3, electrode).value = result
    Exit Do ' go for the next value
End If
If Timer + 3600 < Waittime Then Waittime = Waittime - 86400 ' skip midnight
Loop
' if timeout then result = 0
If Timer >= Waittime Then Worksheets("Results").Cells(3, electrode).value = 0

```

End Sub

Sub SerialFormOpen()

SerialMonitor.Show (vbModeless)

'serialform = True

End Sub

Public Sub StartSerial()

Waittime = Timer + 1

Set MSCommXX = Nothing

Set MSCommXX = New MSComm

With MSCommXX

.CommPort = 1

.Handshaking = 0

.RThreshold = 1

.RTSEnable = True

.Settings = "9600,n,8,1"

.SThreshold = 1

.PortOpen = True

.InputLen = 0 'every character in the buffer is returned

'at any reading

'.Output = "test 1234567890"

End With

SerialMonitor.TextBox1.text = "Port COM1 open, 9600,n,8,1 "

'& MSCommXX.CommEvent & Chr\$(13)

OutText ("DRIVER 1")

'OutText ("X")

serialon = True

```

End Sub
Sub OutText(text As String)
    MSCommXX.Output = text

    'SerialMonitor.TextBox1.text = SerialMonitor.TextBox1.text & Chr$(13) + text
    'If serialform Then SerialMonitor.TextBox1.SetFocus

    End Sub
Sub TypeText(text As String)
    SerialMonitor.TextBox1.text = SerialMonitor.TextBox1.text & text
    If Len(SerialMonitor.TextBox1.text) >= 512 Then SerialMonitor.TextBox1.text = text
    'If serialform Then SerialMonitor.TextBox1.SetFocus
End Sub

Private Function ParseResult(text As String) As Byte

' parse a 8 char text string returned by EVM serial interface
' return 0 in case of error
' X 0D 0A hexdig hexdig 0D 0A >

If Len(text) < 7 Then
    ParseResult = 0
    Exit Function
End If

If Mid(text, 1, 1) <> "X" Then
    ParseResult = 0
    Exit Function
End If

If Mid(text, 2, 1) <> Chr$(13) Then
    ParseResult = 0
    Exit Function
End If

If Mid(text, 3, 1) <> Chr$(10) Then
    ParseResult = 0
    Exit Function
End If

ParseResult = Val("&H" & Mid(text, 4, 2)) ' return value of 2 digit hex reading

End Function

```

Sub deletelog()

'

' deletelog Macro

' Macro recorded 9/6/2003

'

'

```
    Sheets("Results").Select
    Range("L2").Select
    ActiveCell.FormulaR1C1 = "1"
    Sheets("Log").Select
    Cells.Select
    Selection.ClearContents
    Range("A1").Select
    Sheets("Results").Select
    Range("L3").Select
```

End Sub

Sub Average1()

' Average the recorded data to 1 minute interval / establish the position (minimum reading)

Dim logpos, avepos As Integer

Dim value(1 To 9) As Integer

Dim nrvalues As Integer

Dim k As Byte

Dim a As Date

' delete old values first

```
Sheets("Average").Select
```

```
    Cells.Select
```

```
    Selection.ClearContents
```

```
    Range("A1").Select
```

logpos = 1

avepos = 1

lasttime = Worksheets("Log").Cells(logpos, 1).value ' read initial value

lasttime = lasttime + 60 ' add 1 minute interval

If lasttime > 86400 Then

```
    lasttime = lasttime - 86400 ' skip midnight
```

```
    Do While ((lasttime <= Worksheets("Log").Cells(logpos, 1).value) And  
(Worksheets("Log").Cells(logpos, 1).value <> ""))
```

```
        logpos = logpos + 1
```

```
    Loop
```

End If

```

' get initial values
nrvalues = 0
For k = 1 To 9
    value(k) = 0
Next k
'look for 1 minute intervals
Do While Worksheets("Log").Cells(logpos, 1).value <> ""
    'DoEvents
    If Worksheets("Log").Cells(logpos, 1).value < lasttime Then
        For k = 1 To 9
            value(k) = value(k) + Worksheets("Log").Cells(logpos, 2 + k).value
        Next k
        nrvalues = nrvalues + 1
        logpos = logpos + 1
    Else
        ' compute the average, store the average in the average table and go to next minute
        ' logpos - do not change
        Worksheets("Average").Cells(avepos, 1).value = Worksheets("Log").Cells(logpos
- 1, 1).value
        a = Worksheets("Log").Cells(logpos - 1, 2).value
        Worksheets("Average").Cells(avepos, 2).value = a
        ' start with position 1 as reference
        minimum = value(1) / nrvalues
        minpos = 1
        For k = 1 To 9
            ' avoid divide by 0
            If nrvalues <> 0 Then
                Worksheets("Average").Cells(avepos, 2 + k).value = value(k) / nrvalues
                If (value(k) / nrvalues) < minimum Then
                    minimum = (value(k) / nrvalues)
                    minpos = k
                End If
            Else
                Worksheets("Average").Cells(avepos, 2 + k).value = 0
            End If
        Next k
        Worksheets("Average").Cells(avepos, 12).value = nrvalues
        Worksheets("Average").Cells(avepos, 13).value = minimum
        Worksheets("Average").Cells(avepos, 14).value = minpos

        avepos = avepos + 1

        ' reinit average
        nrvalues = 0
        For k = 1 To 9
            value(k) = 0

```

```

Next k
  lasttime = Worksheets("Log").Cells(logpos, 1).value
  lasttime = lasttime + 60 ' next 1 minute interval
  If lasttime > 86400 Then
    lasttime = lasttime - 86400 ' skip midnight
    ' skip values until the next day

    Do While ((lasttime <= Worksheets("Log").Cells(logpos, 1).value) And
(Worksheets("Log").Cells(logpos, 1).value <> ""))
      logpos = logpos + 1
    Loop

  End If
End If
Loop
  ' rebuild chart
  avepos = avepos - 1
  If avepos <> 0 Then ' empty table
    Sheets("Position VS Time").Select
    ActiveChart.SeriesCollection(1).Values = "=Average!R1C14:R" &
Trim(Str(avepos)) & "C14"
    ActiveChart.SeriesCollection(2).Values = "=Average!R1C13:R" &
Trim(Str(avepos)) & "C13"
    ActiveChart.SeriesCollection(1).XValues = "=Average!R1C2:R" &
Trim(Str(avepos)) & "C2"
  End If
End Sub

```